



eliza gabriel 

COLLECTION CAMU-CAMU / ETE 2007
COLLECTION MANDACARU / HIVER 2006

PETALAS

Technique de “compression”.
Assemblage de ronds de
tissus pliés en quatre et
cousus serrés les uns à côté
des autres.

Ce type de technique par son
résultat, donne l’impression
des pétales de rose, les sacs
ainsi faits sont des “bouquets
de fleurs”.

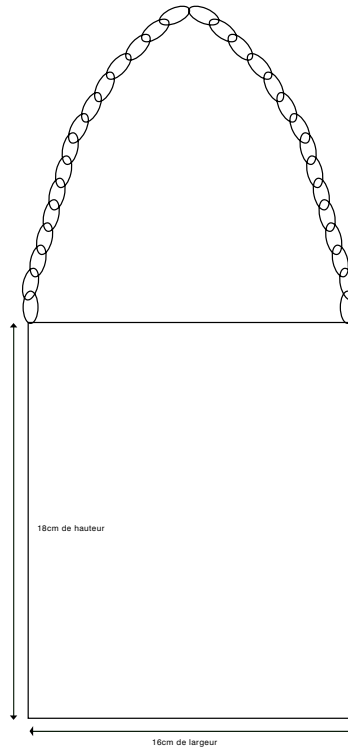

RECTANGULAIRE

ROND

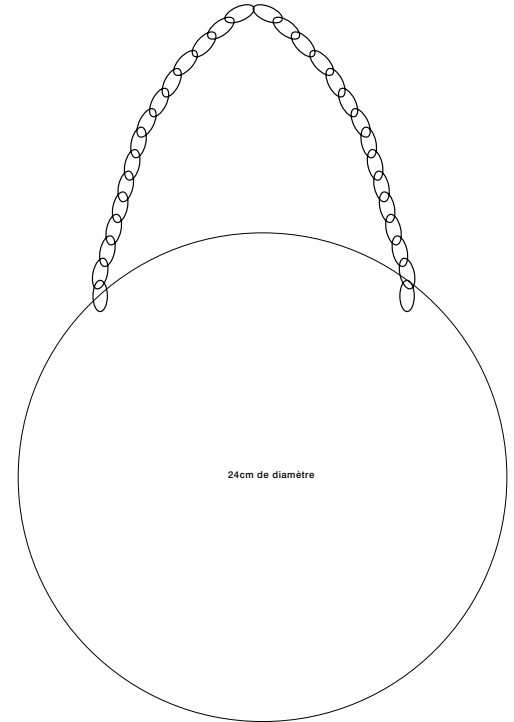

Un simple noeux vous permettra de transformer la anse perlé en collier.
Ce modèle peut aussi être porté en bandulière (anse en satin).

Sac petalas rectangle anse perlé





Sac petalas rond anse perlé

Sac petalas rectangle anse perlé











Col musseline



Col malha

PUDOOL

Technique "poils de chien".
Assemblage en franges de
longs morceaux de tissus
cousus les uns à côté des
autres.

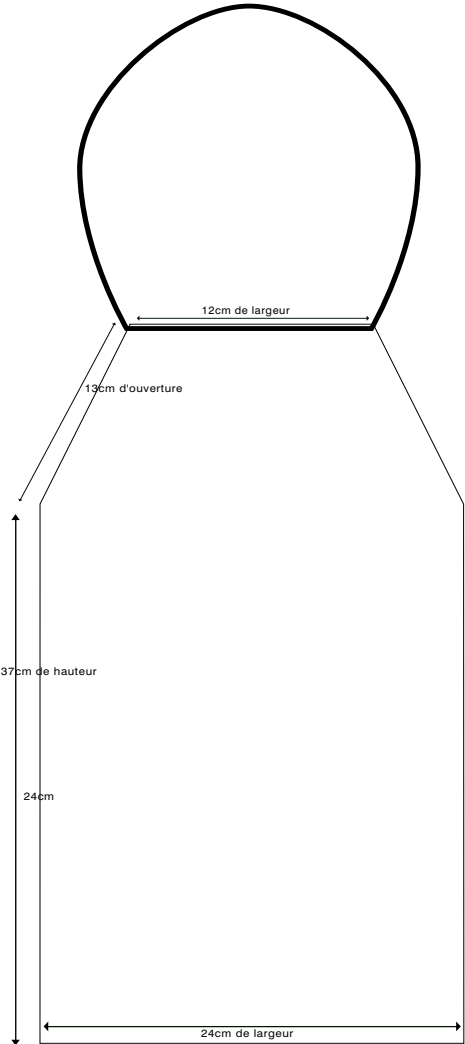



Sac pudoll long anse métal



NISSEI

Technique en “strates”.

Superposition de plusieurs couches de tissus assemblés, cousus, puis coupés formant un “millefeuille”. Nisseï (ni=deuxième, sei=génération) fils d’imigrants japonais qui sont nés au Brésil.

Ce type de technique, la façon de travailler, et sont résultat donnent le non Nisseï à cette ligne de sacs.

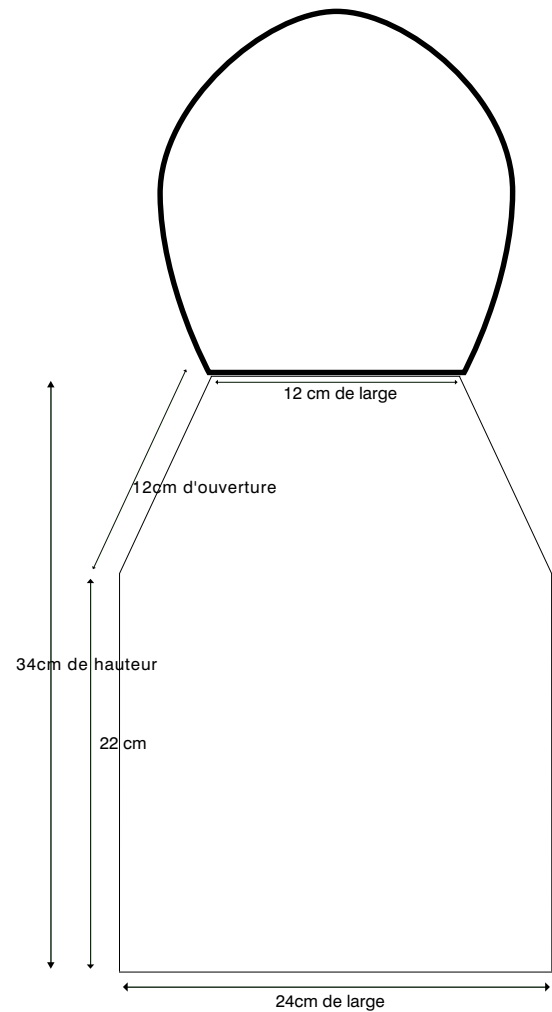





Sac nissei bandulière petit





Col nissei



Ceinture

FROUFROU

Technique de “compression”.

Assemblage de carrés de tissus cousus serrés les uns à côté des autres, puis “frisés” par la machine à coudre.



REF. FRU-MA-BAND-G

Sac froufrou bandulière grand



ELIZA GABRIEL
15, rue Croas Talud
29100 Douarnenez
tél. 06 63 93 36 13
mail : lioza@wanadoo.fr
site : www.elizagabriel.com (en cours)